

A

B

C

D

E

F

G

H

e-LINE DUPLEX CONTROL PANEL

115-230 VOLT / 60 HZ / 1 PHASE

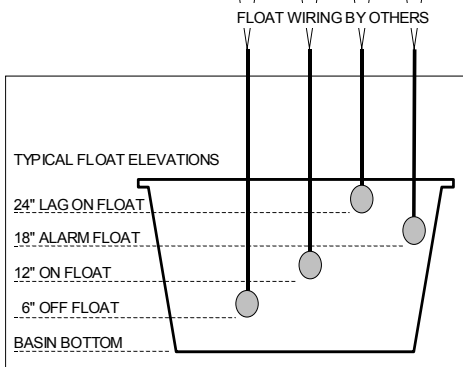
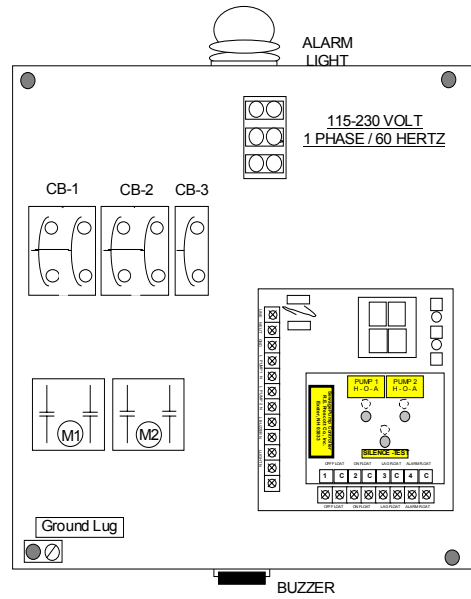
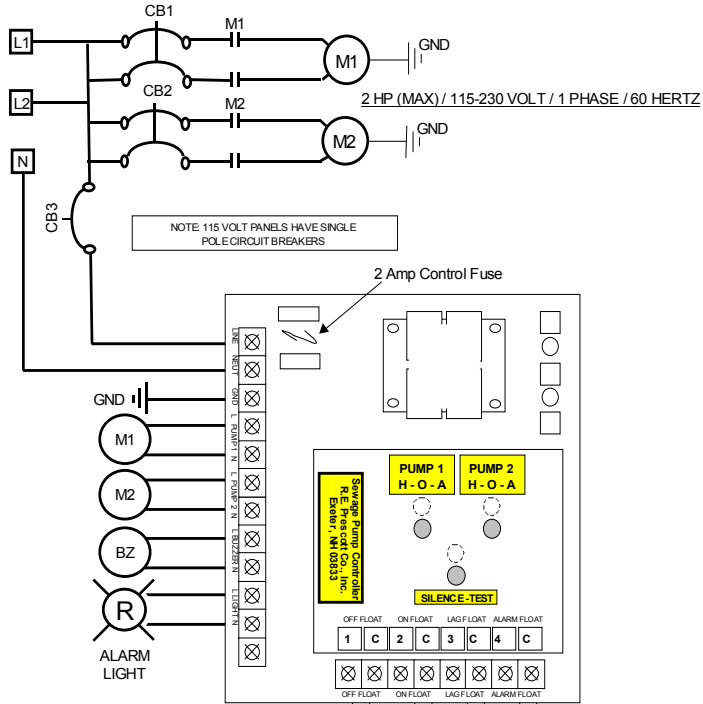

MODEL: e-LINE DUPLEX v2.0
VOLTS: 115 / 230 **MAX HP:** 2.0
HERTZ: 60 **PHASE:** 1

CONNECT CABINET TO A GOOD GROUND
 DISCONNECT POWER BEFORE SERVICING

REPLACE FUSES WITH A 2AG OR EQUIVALENT FUSE

FOR FIELD WIRING USE COPPER CONDUCTOR 60
 DEGREE INSULATION

CAUTION: TO REDUCE THE RISK OF FIRE, REPLACE
 ONLY WITH THE SAME TYPE AND RATING OF FUSE
 (OR EQUIVALENT)

TORQUE SCREWS TO 20 LB.IN.

-000
 -010
 -020
 -030
 -040
 -050
 -060
 -070
 -080
 -090
 -100
 -110
 -120
 -130
 -140
 -150
 -160
 -170
 -180
 -190
 -200
 -210
 -220
 -230
 -240
 -250

eLINE REPCO CONTROLS
 DUPLEX CONTROL PANEL
 WITH HIGH WATER ALARM



R.E. PRESCOTT CO., INC.
 10 RAILROAD AVENUE
 EXETER, NH 03833